

# MILD STEEL SCREWED PIPE FITTINGS

## BS EN 10241

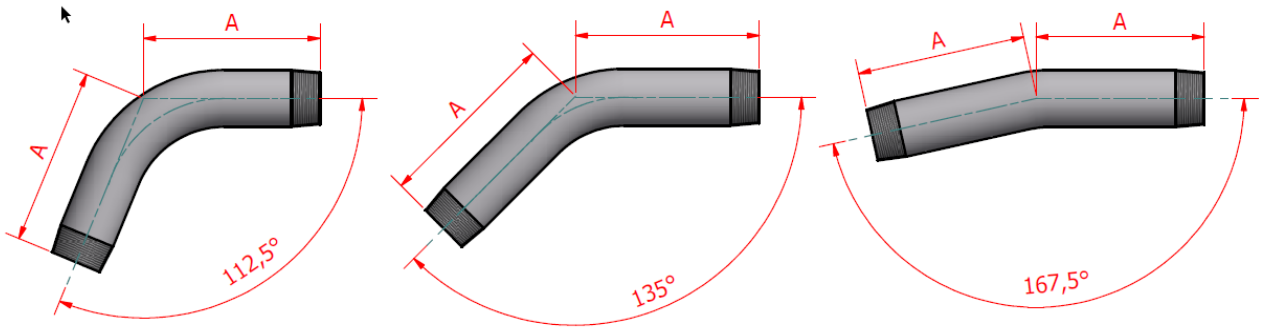

### Spring bend

Nominal bore		Approx. centre to face dim. A			Approx. centre line radius dim. R	Weight each bend only	Weight each including socket
		112.5°	135°	167.5°			
Metric	Imperial	mm	mm	mm	mm	kgs	kgs
6mm	1/8"	48	44	44	32	0.03	0.05
8mm	1/4"	60	57	54	41	0.07	0.11
10mm	3/8"	67	64	60	48	0.10	0.15
15mm	1/2"	79	76	73	50	0.16	0.24
20mm	3/4"	92	89	86	60	0.26	0.36
25mm	1"	108	105	102	70	0.50	0.65
32mm	1 1/4"	133	127	124	89	0.76	1.00
40mm	1 1/2"	149	143	140	105	1.00	1.32
50mm	2"	181	175	168	127	1.66	2.13
65mm	2 1/2"	222	213	206	180	2.84	3.55
80mm	3"	260	248	241	205	4.54	5.56
100mm	4"	340	324	318	297	8.93	11.03
125mm	5"	476	457	444	377	13.87	16.37
150mm	6"	572	540	527	437	19.07	21.97

Bends are also available with plain or chamfered ends.